

1. When cleaning the rubber roller, please wipe it with a soft cloth dipped in gasoline or neutral detergent, and then wipe it with a dry cloth. It is forbidden to scrape with hard materials such as metal sheets.

2. Lubricating oil needs to be added to the rotating screw regularly. The rubber roller of this machine adopts a special formula process, which has first-class high resilience and anti-aging properties. However, when not in use for a long time, the upper and lower rubber rollers should be separated immediately to prevent the rubber rollers from being deformed due to extrusion for a long time.

Cold Laminator Manual

SRL-C160



Step 1: Tripod installation attempt

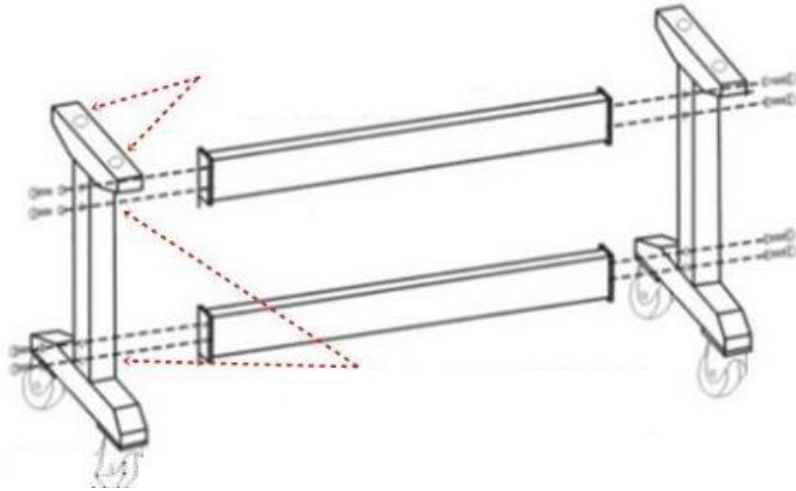

ensure that the upper and lower rubber rollers touch in parallel. When the pressure at both ends is equal, and then pressurized slightly, the pressure should not be too heavy to avoid bubbles and wrinkled film during mounting. Then shake the right hand wheel and the machine will work.

Step 2: Operation Instructions

The mounting pressure can be adjusted at the left and right ends of the machine. First separate the rubber rollers, and then align the cold lamination film and the picture on the lower rubber roller. Turn the knob to